

Basic Training: Circuits

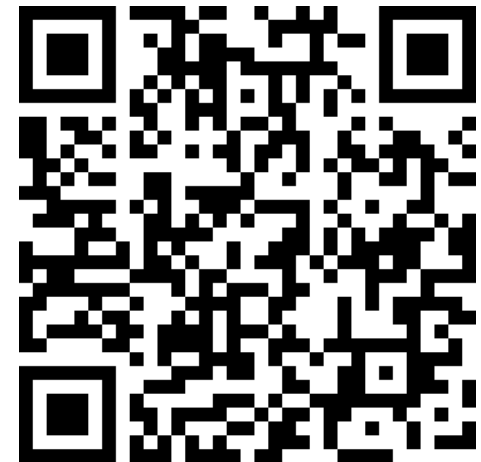















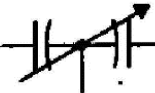





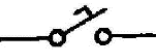

Al Klase – SP-5, U.S. Army Signal Corps 1968-1971

20 Mar 2022

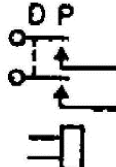
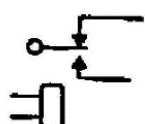
Get your own copy.

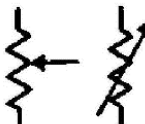

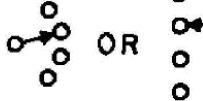
SCHEMATIC SYMBOLS USED IN CIRCUIT DIAGRAMS

<p>* Insert Appropriate Designations A - Ammeter V - Voltmeter mA - Milliammeter etc. METERS</p> 	  <p>Multicell Single cell BATTERIES</p>	     <p>Electrolytic Fixed Variable Split-stator Feedthrough CAPACITORS</p>						
 <p>MICROPHONE</p>	 <p>ANTENNA</p>	 <p>CRYSTAL QUARTZ</p>	 <p>FUSE</p>	 <p>GROUND</p>	 <p>HEADSET</p>	  <p>Hand Foot KEYS</p>	  <p>Pilot Neon (A C) LAMPS</p>	
<p>SP DP SPDT</p>    <p>RELAYS</p>			   <p>Fixed Tapped Adjustable RESISTORS</p>			   <p>SPST SPDT OR Toggle Multipoint SWITCHES</p>		 <p>SPEAKER</p>

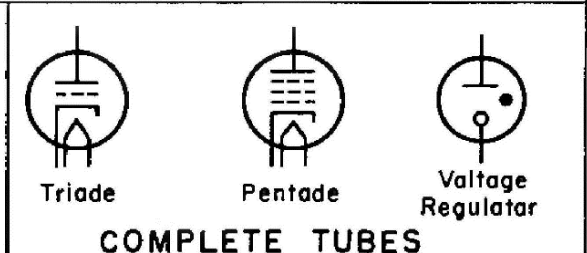
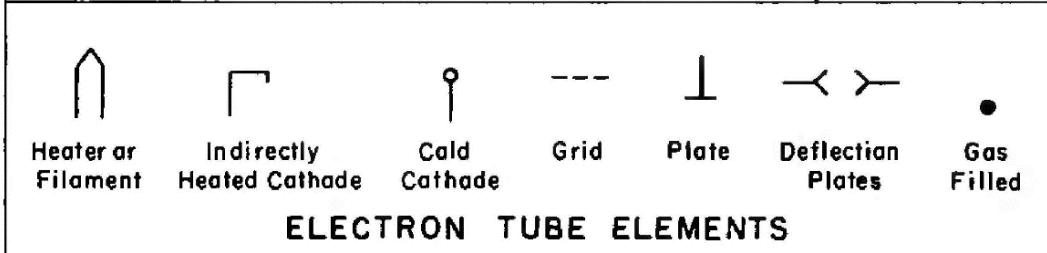
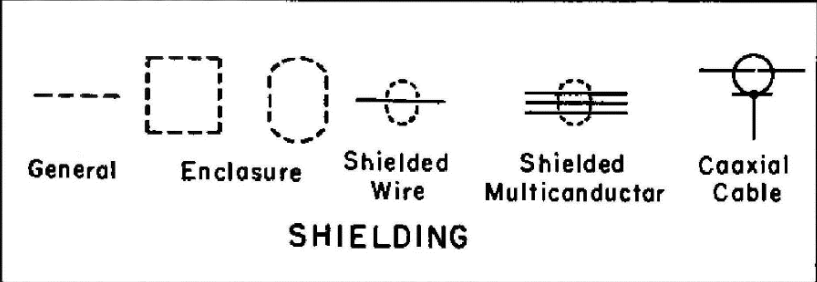
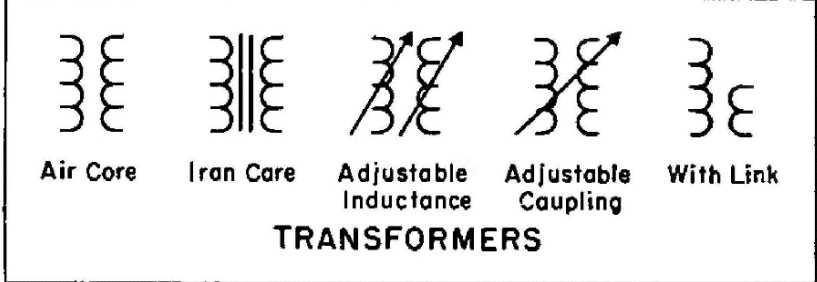
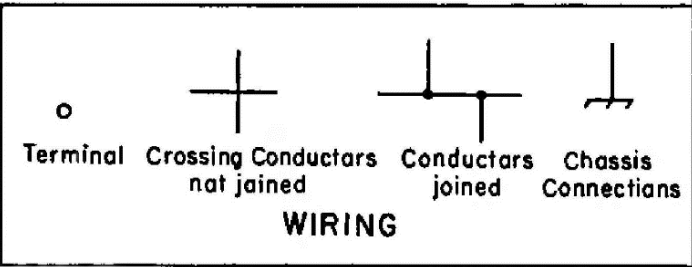
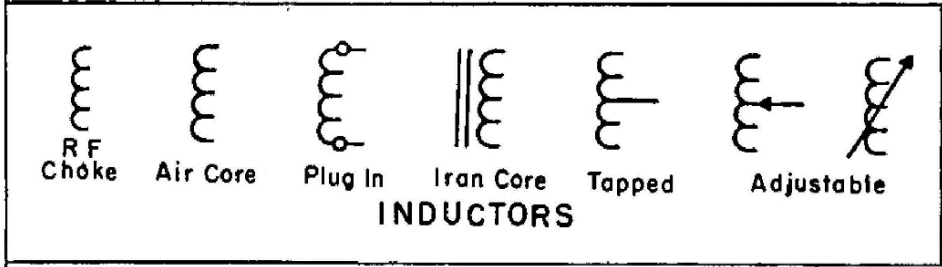
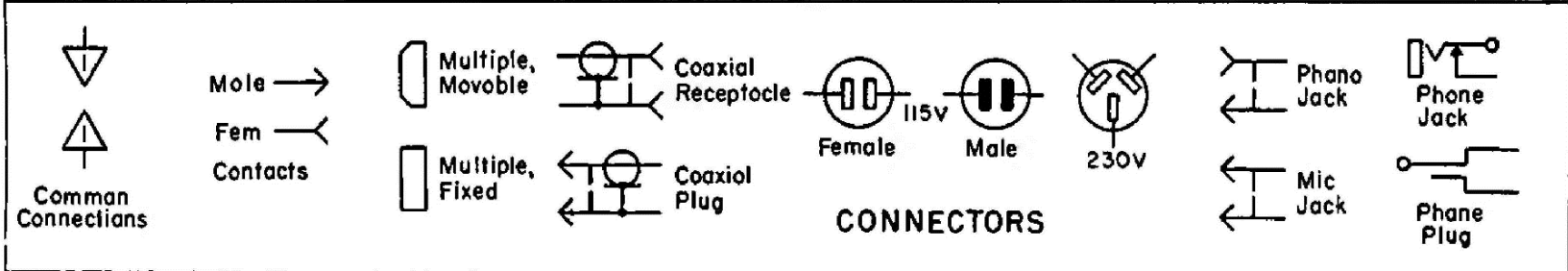
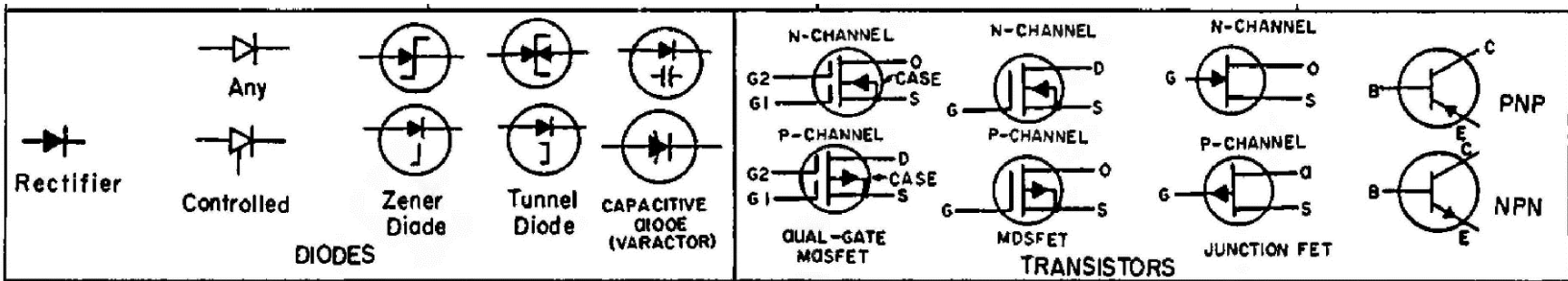

A Simple Circuit

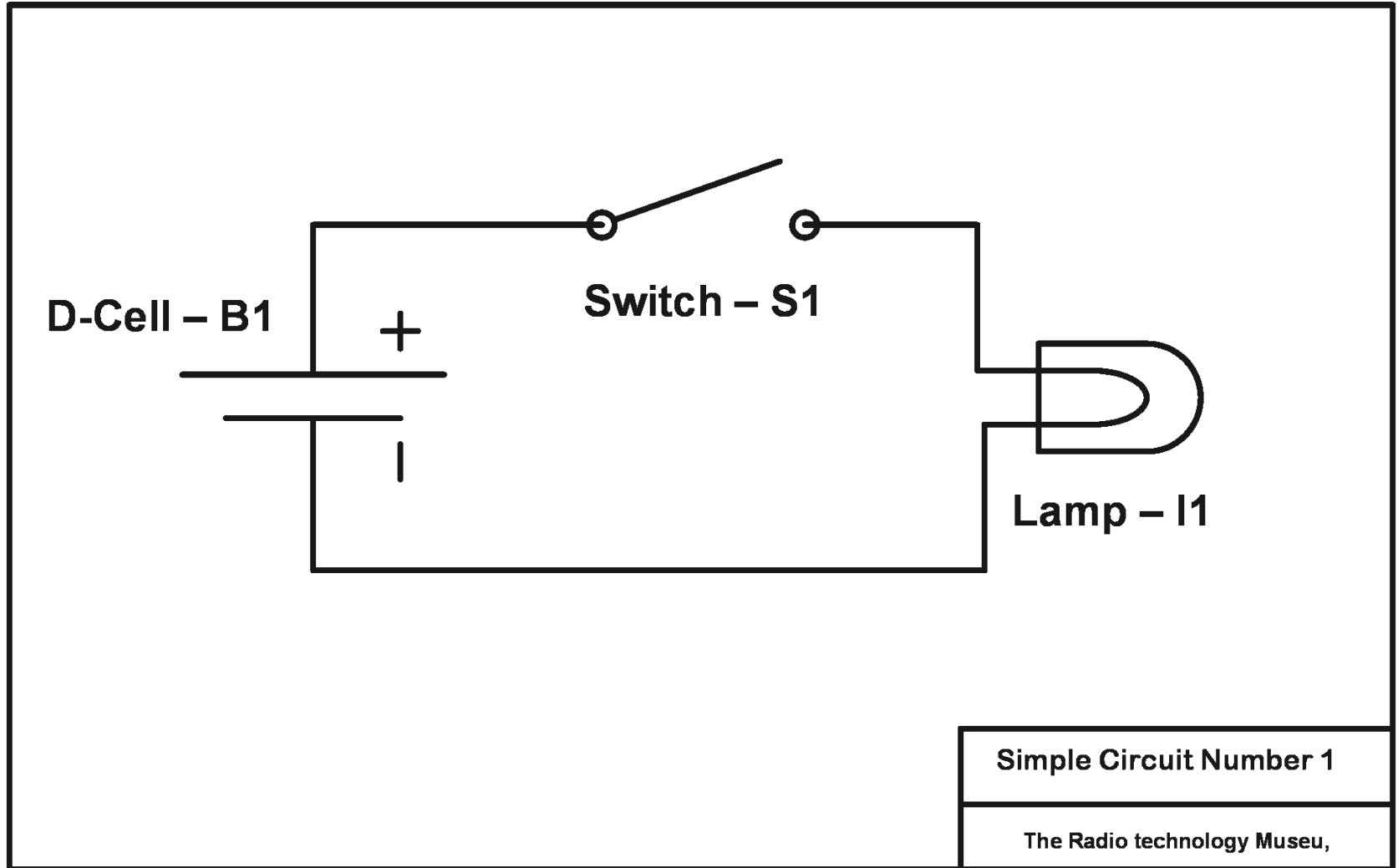

Round Up the Parts

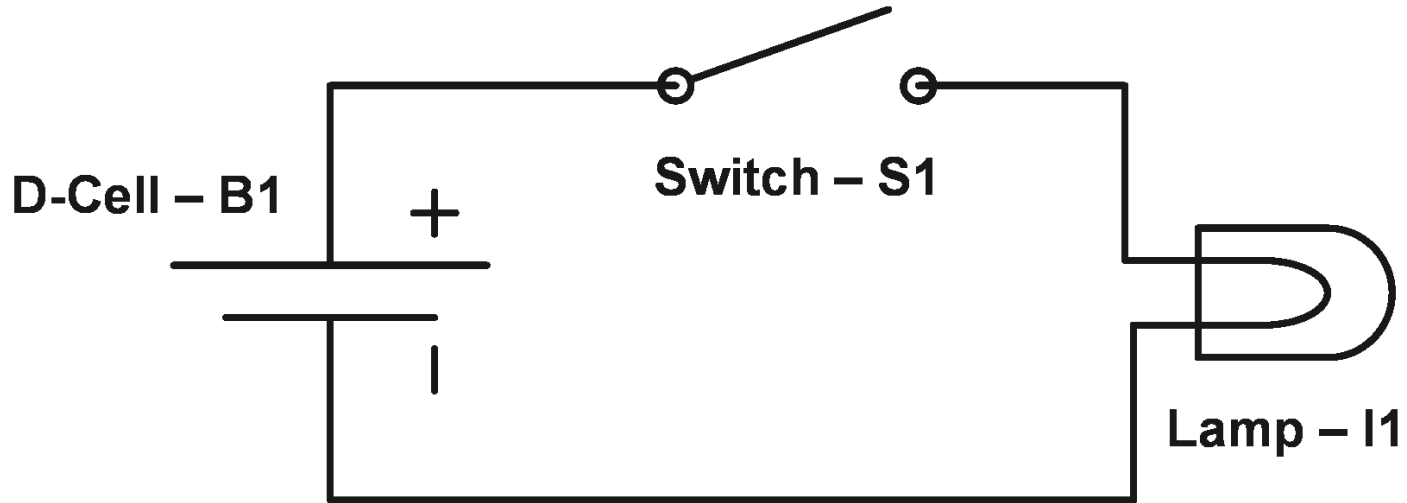

How many pieces of wire will you need?

Assemble the Circuit

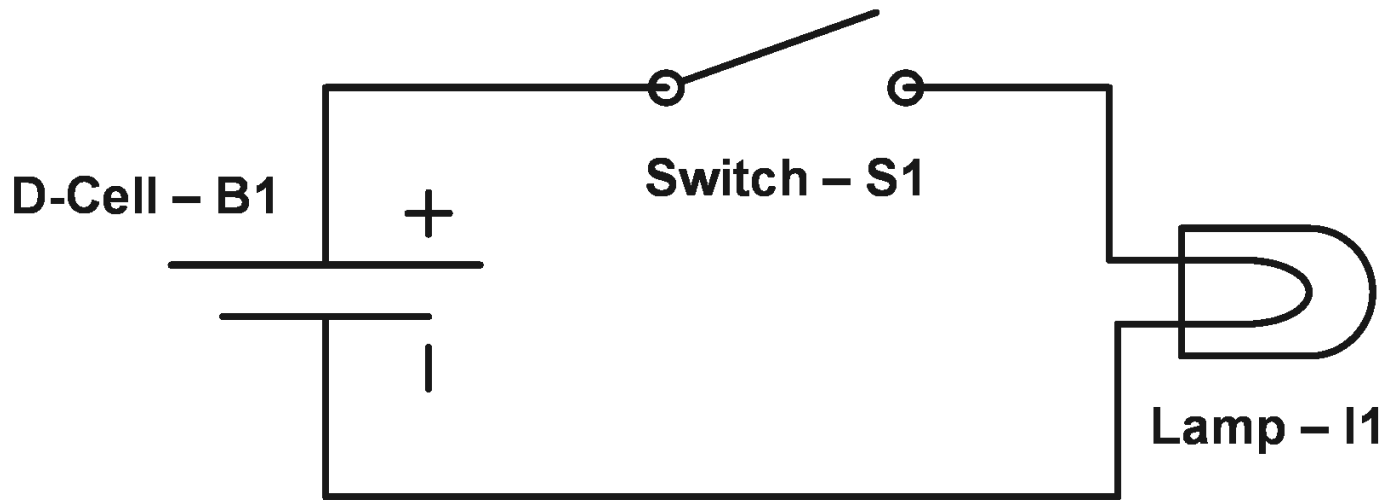

Not This Way!

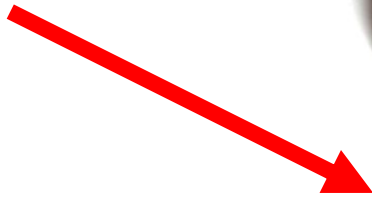

This Way!

The same direction as
tightening the terminal



The Digital Multi-Meter

The Technician's Best Friend

- Lots of choices
- Microelectronics allows many functions
- Inexpensive
- This one:
 - Borbete 168B
 - \$21 on Amazon



DMM Functions

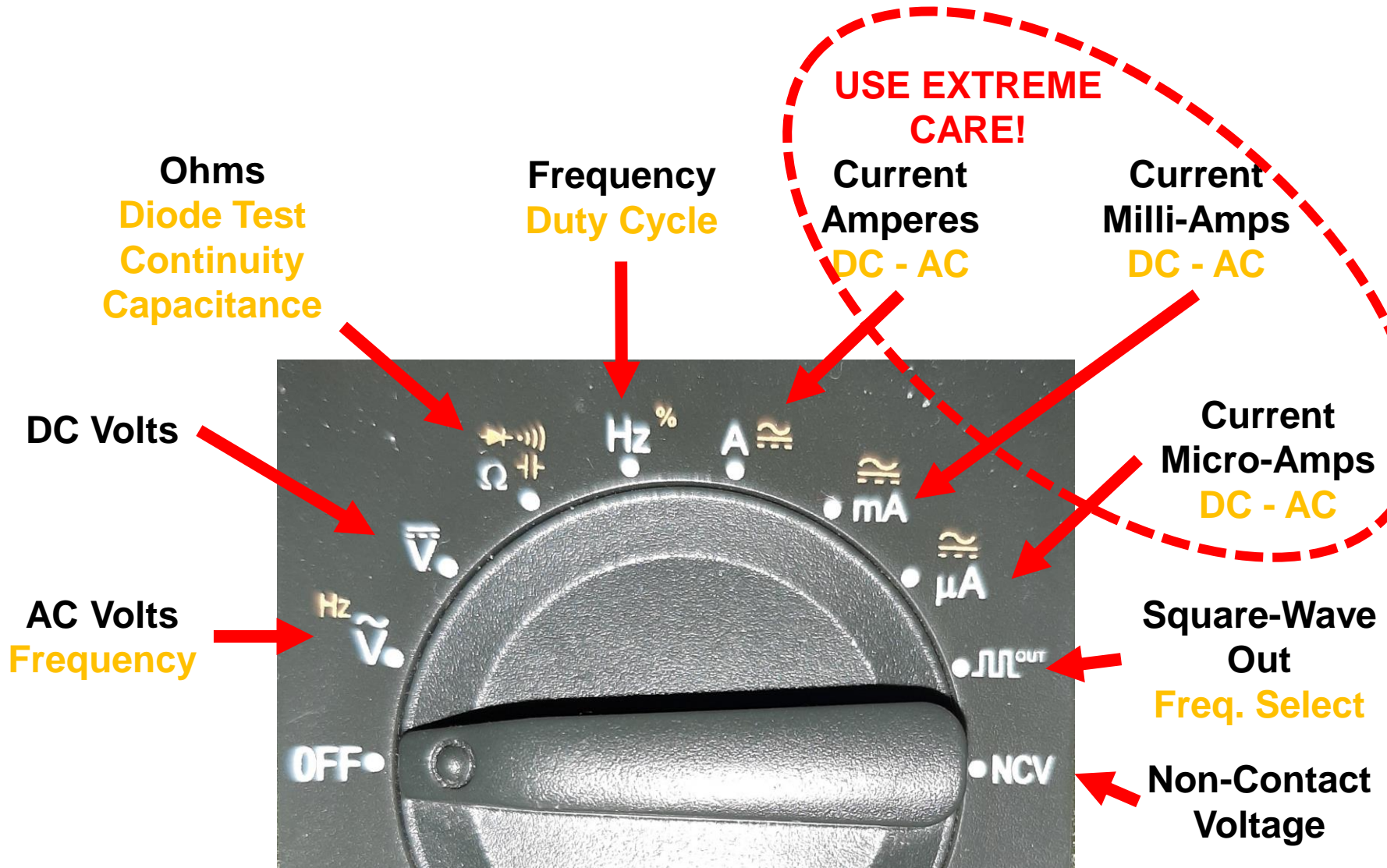

Test the D-Cell

- Red Lead Connected to “VΩHzmA”
- Black Lead to “COM”
- Function Switch to “V”
- Switch – S1 OPEN
- Touch the probes to both sides of the D-Cell.
- Record the open circuit voltage.

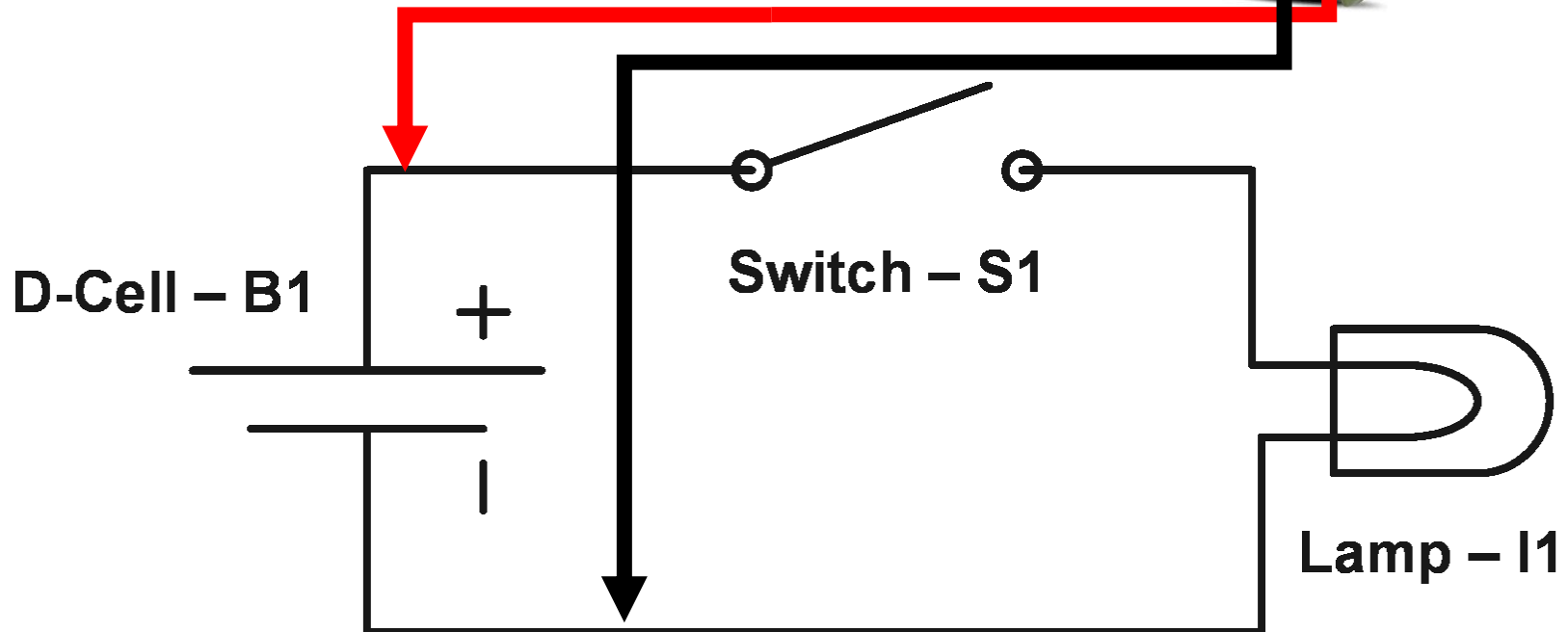
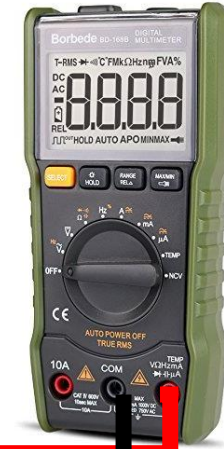

Test the Lamp

- Red Lead Connected to “VΩHzmA”
- Black Lead to “COM”
- Function Switch to “Ω”
- Switch – S1 OPEN
- Touch the probes to both sides of the lamp Socket.
- Record the lamp-filament cold resistance.

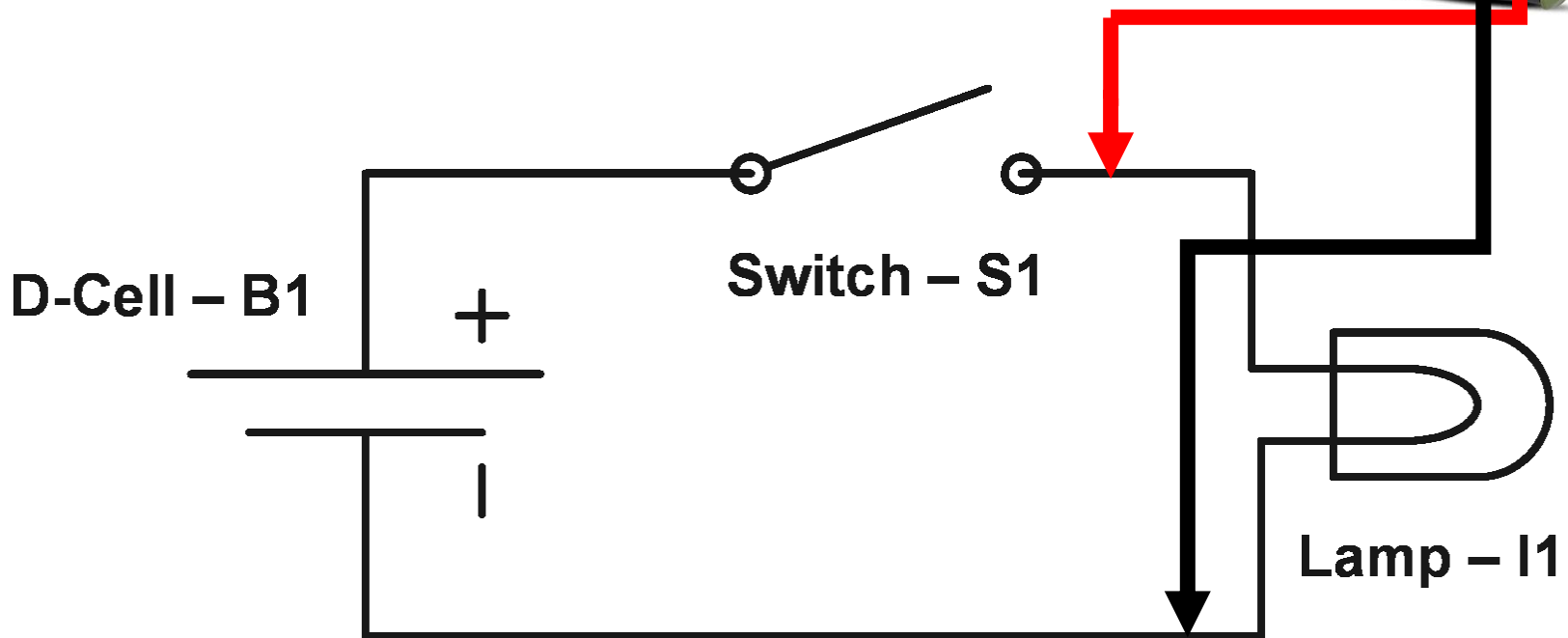

Measure the Current

- Red Lead Connected to “10A”
- Black Lead to “COM”
- Function Switch to “A”
- Switch – S1 OPEN
- Touch the probes to both sides of the open switch.

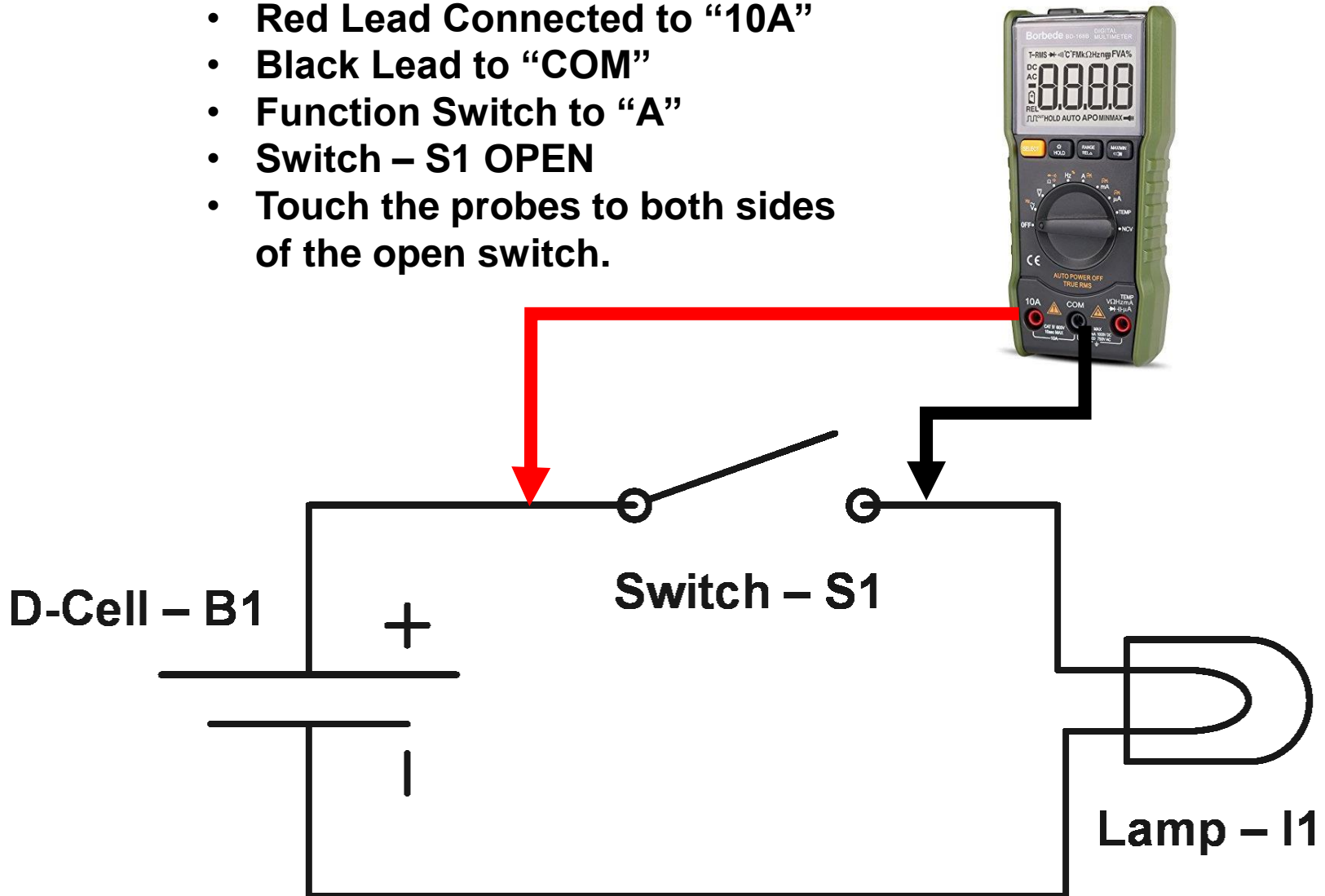

Measure the Lamp Voltage

- Red Lead Connected to “VΩHzmA”
- Black Lead to “COM”
- Function Switch to “V”
- Switch – S1 Closed
- Touch the probes to both sides of the lamp Socket.
- Record the lamp Voltage.

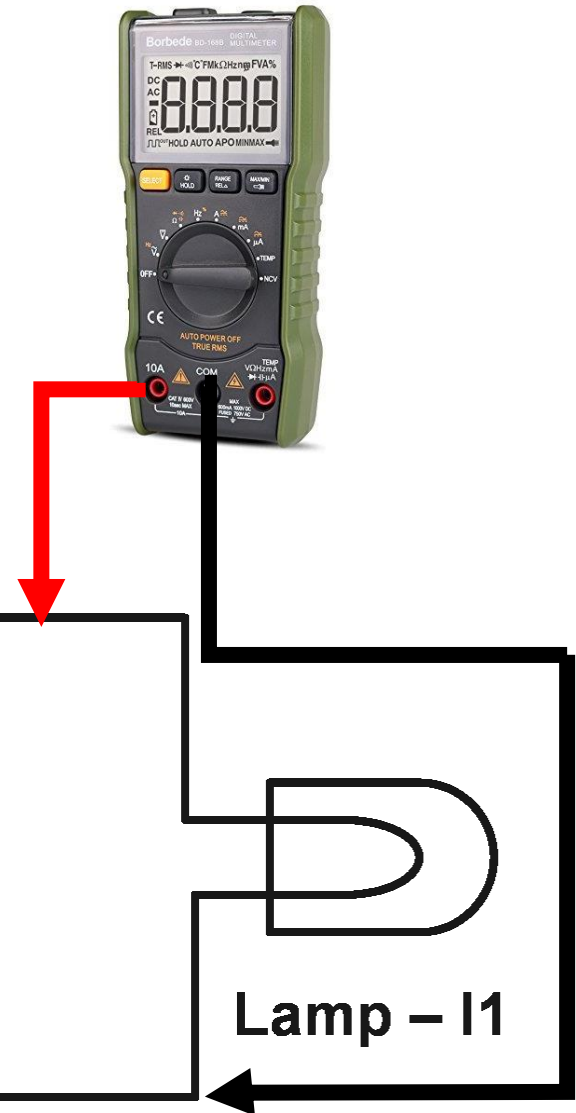

Test Results

- D-Cell open-circuit voltage _____
- Lamp resistance (cold) _____
- Lamp current (i) _____
- Lamp Voltage (e) _____

Calculations:

- Lamp power consumption: $e \times i =$ _____
- Lamp resistance (hot) : $\frac{e}{i} =$ _____

Cheat Sheet

Voltage, Current, Power, and Resistance

Ohm's Law

$$E = I \times R$$

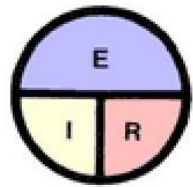

I = AMPERES (CURRENT)
R = OHMS (RESISTANCE)
E = VOLTS (ELECTROMOTIVE FORCE)

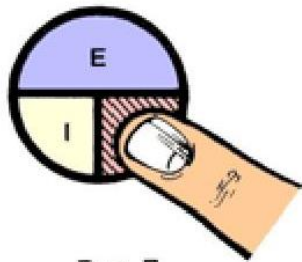

$$R = \frac{E}{I}$$



$$E = I \times R$$

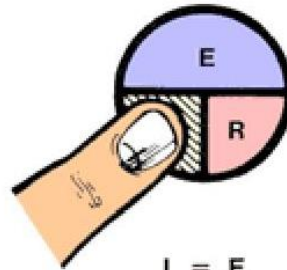

$$I = \frac{E}{R}$$

Other Relationships

